

# NV-7500 5" MUD GATE VALVE

with Proprietary M2M™ Seat Technology



The Premium Oilfield Technologies Model NV75 Mud Gate Valve uses M2M™ sealing technology. This technology allows our valve to be one of the longest lasting valves in the industry and is used in applications up to 7500 psi. Unlike conventional mud valves with rubber seats that wash out quickly, the NV75 uses single piece seat rings creating an upstream metal to metal seal. This upstream design helps eliminate debris contamination into the valve body and reduces wear on internal components.

## BENEFITS

- ◆ Single piece seat
- ◆ Metal to metal sealing
- ◆ Reduced wash-outs: Upstream sealing reduces solids in valve cavity
- ◆ High performance urethane stem packing
- ◆ Stainless steel stem, gate and seats. Forged bonnet
- ◆ Certificates available up to API PSL-2

## APPLICATIONS

- ◆ 7500 psi mud systems
- ◆ Standpipe manifolds
- ◆ MPD manifolds
- ◆ Bleed lines
- ◆ 5" full bore, butt-weld or flanged

Dim	6" XXH	5-1/8" 10K Flanged
A	19.33	19.33
B	24.00	24.00
C	6.50	6.50
D	17.88	29.00

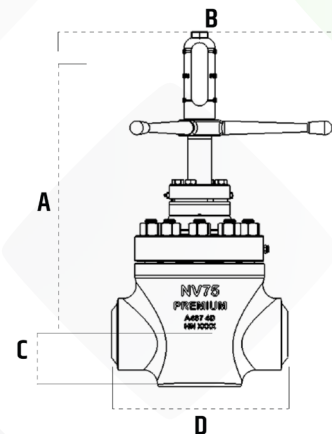

# 5" NV-7500 MUD GATE VALVE

with Proprietary M2M™ Seat Technology

Item #	Part #	Kit	Description	QTY
	501-6610		Assembly, NV75 5" Gate Valve, Weld Ends	
	501-6620		Assembly, NV75 5" Gate Valve, Flanged Ends	
	501-6660	X	Minor Repair Kit , Includes Y	
	501-6650	Y	Major Repair Kit , Includes X	
1	501-6680		Body, Finish Machined, Weld End, NV75 5" Gate Valve	1
2	501-6673	XY	Spring, Seat, NV75 5" Gate Valve	2
3	501-6672	XY	Seat, NV75 5" Gate Valve	2
4	3H9-2360	XY	O-Ring, Size 2-360, .210 X 5.850 ID , HBNR 90 Duro	2
5	501-6676		501-6676 Bonnet, NV75 5" Gate Valve, Modified from 501-1350 W/ 1/4 NPT Hole	1
6	3H9-2446	XY	O-Ring, Size 2-446, .275 X 8.475 ID, HBNR 90 Duro	1
7	501-1301	X	Bushing, Stem, MR7500 5" Gate Valve	1
8	501-1302	X	Packing, Stem Seal, 1.25 ID, 1.75 OD .860 Height	1
9	501-1290		Retainer, Packing, MR7500 5" Gate Valve	1
10	3H9-2218	X	O-Ring, Size 2-218, 0.139 X 1.234 ID, HBNR 90 Duro	1
11	205-1057		Cap Screw, Socket Head,.625-11 UNC, ASTM A574	4
12	601-0122	X	Bearing Thrust, 75mm ID, 100mm Od, 6mm Thick	2
13	501-1260	X	Stem Screw, MR7500 5" Gate Valve	1
14	501-1270		Housing, Screw, MR7500 5" Gate Valve	1
15	601-0125	X	Wiper, 3.00" Rod, Medium Duty DT Type Seal	1
16	202-1495		Cap Screw, Hex Head, 0.75-9unc X 4.00" Long	4
17	601-0009		Zirk, Grease 1/8" NPT	1
18	501-6675	X	Stem, NV75 5" Gate Valve	1
19	501-1330	XY	Clip, Gate, MR7500 5" Gate Valve	1
20	501-6671	XY	Gate, NV75 5" Gate Valve	1
21	501-1200		Handwheel, Finish Machine, MR7500 5" Gate Valve	1
22	501-1220		Screw, Handwheel, MR7500 5" Gate Valve	1
23	501-1230		Tube, Stem, MR7500 5" Gate Valve	1
24	501-1240		Stem Cap, MR7500 5" Gate Valve	1
25	501-1400		Stud, Tapend, 1.250-8un X 6.375 Long	12
26	209-019		Nut, Heavy Hex, 1.250-8un, ASTM A194 GR. 2h	12
27	601-0220		Grease Fitting, Button Head, 7/8 Coupler X 1/4 NPT, W/Pressure Relief	1

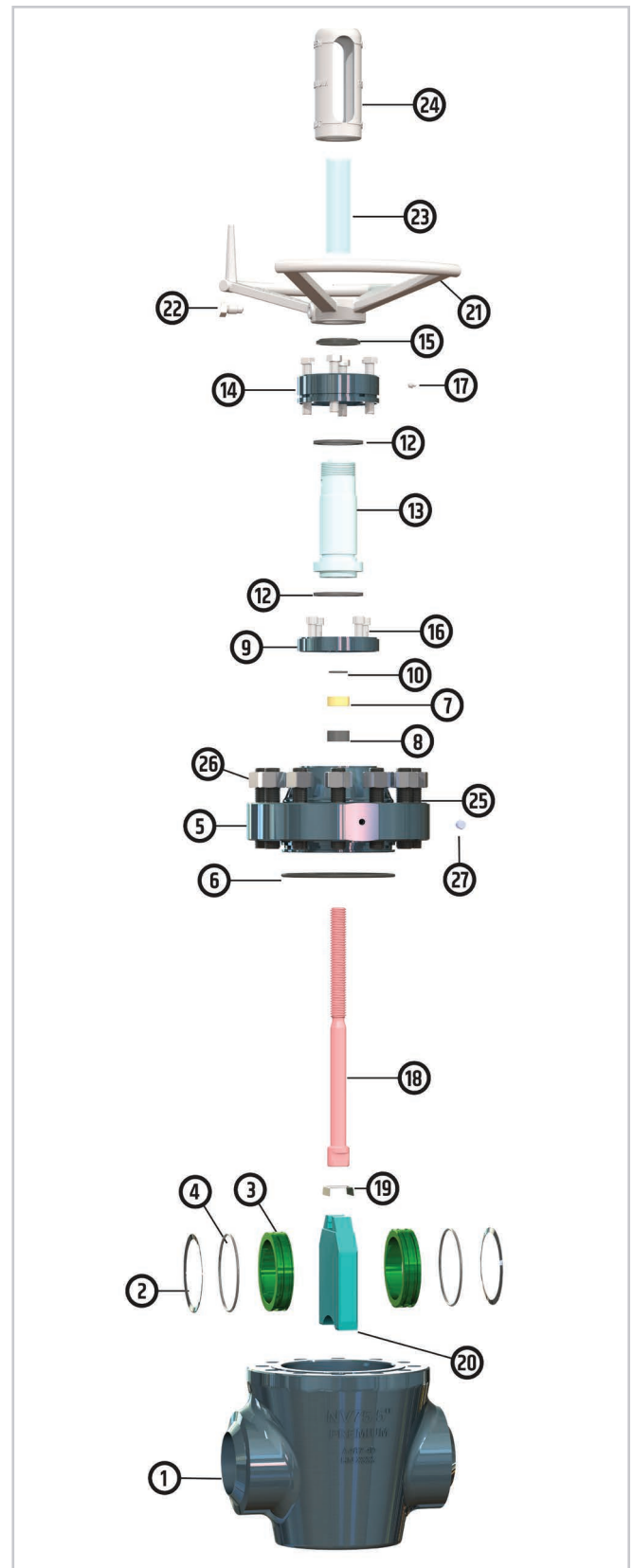

Premium Oilfield  
Technologies  
Q1-3977

Premium Oilfield Technologies  
10600 W. Sam Houston Pkwy North  
Houston, Texas 77064  
281.670.5200 ♦ [premiumoilfield.com](http://premiumoilfield.com)